

PRODUCT SPECIFICATION



Part No. : JH-3030RGBW12GE24-T7A-G
High Power LED

Catalog

1.Product Features	P2
2.Dimensions	P2
3.Absolute Maximum Rating	P3
4.Optical Character	P3
5.Optical Character Curves	P4
6.Spectrum Curves	P5
7.Viewing Angle Curves	P5
8.Soldering Advice	P6
9.Cautions	P7

1.Product Features

- High Brightness RGBW LED Round Package
- Viewing Angle 120 Degree
- Transparent Silicone
- Chip Material: AlGaInP
- RoHS Compliant

2.Dimensions

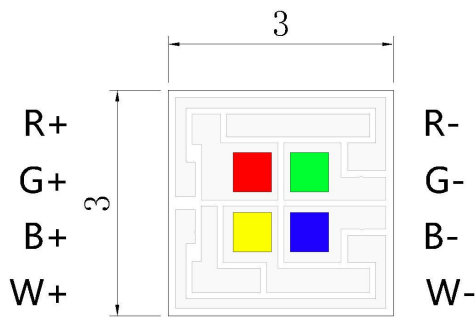

Top view

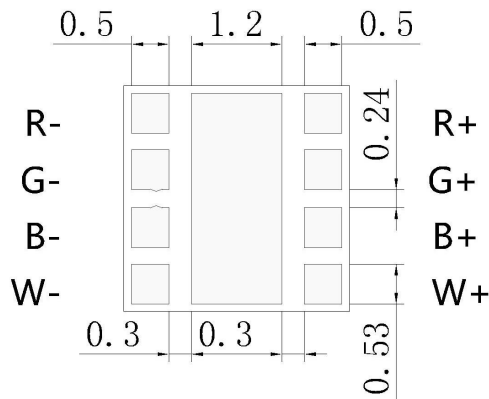

Bottom view

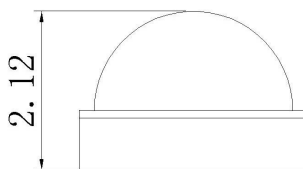

Side view

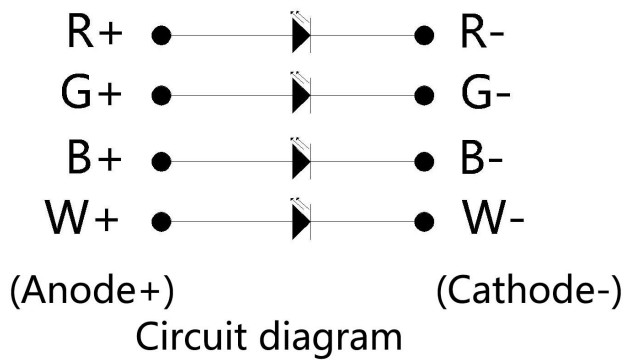

Notes:

1. All dimensions are in millimeters.
2. Tolerance is $\pm 0.1\text{mm}$ unless otherwise noted.

3. Absolute Maximum Rating @ Ta=25° C

Parameter	Symbol	Maximum Rating	Unit
Continuous Forward Current	IF	350	mA
Peak Forward Current (1/10 Duty Cycle, 0.1ms Pulse Width)	IFp	500	mA
Reverse Voltage	VR	5	V
Power Dissipation	PD	4	W
Electrostatic Discharge	ESD	1000	V
Operating Temperature Range	TOPR	-25°C to +80°C	
Storage Temperature Range	TSTG	-35°C to +100°C	
Lead Soldering Temperature	TSOL	260°C	

4. Optical Character @ Ta=25° C

Parameter	Symbol	Color	Min.	Typ.	Max.	Unit	Test Condition
Forward Voltage	VF	R	2.0	2.2	2.4	V	IF=150mA
		G	3.0	3.2	3.4	V	IF=150mA
		B/W	3.0	3.2	3.4	V	IF=150mA
Luminous Flux	Φ	R	15	20	25	Lm	IF=150mA
		G	30	35	40	Lm	IF=150mA
		B	7	10	12	Lm	IF=150mA
		W	50	55	60	Lm	IF=150mA
Dominant Wavelength	Wld	R	620	622.5	625	nm	IF=150mA
		G	520	523	525	nm	IF=150mA
		B	460	463	465	nm	IF=150mA
Color Temperature	Tc	W	5500	6000	6500	K	IF=150mA
Reverse Current	IR				10	μA	VR=5V
Viewing Angle	2θ1/2				120	deg	IF=150mA
Recommend Forward Current	IF(rec)	RGBW			150	mA	

Notes:

Measurement tolerance of forward voltage ±0.1V

5. Optical Character Curves

(25 ° Ambient Temperature Unless Otherwise Noted)

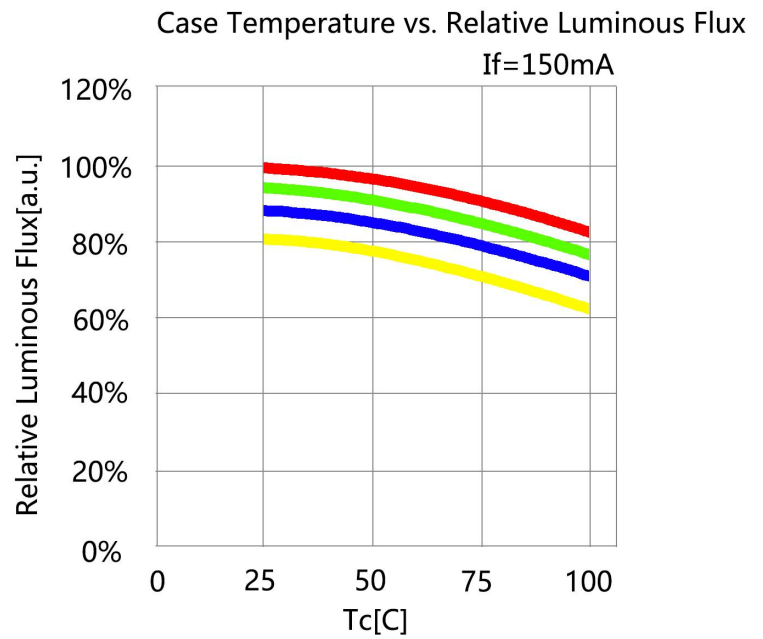
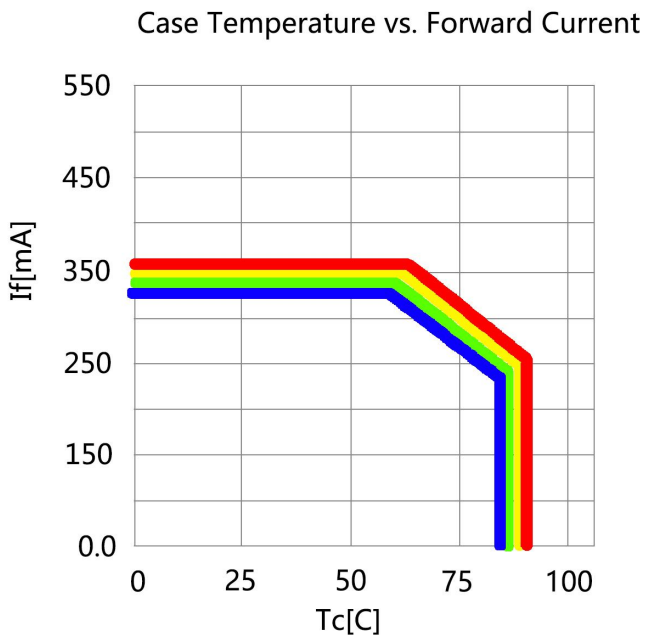
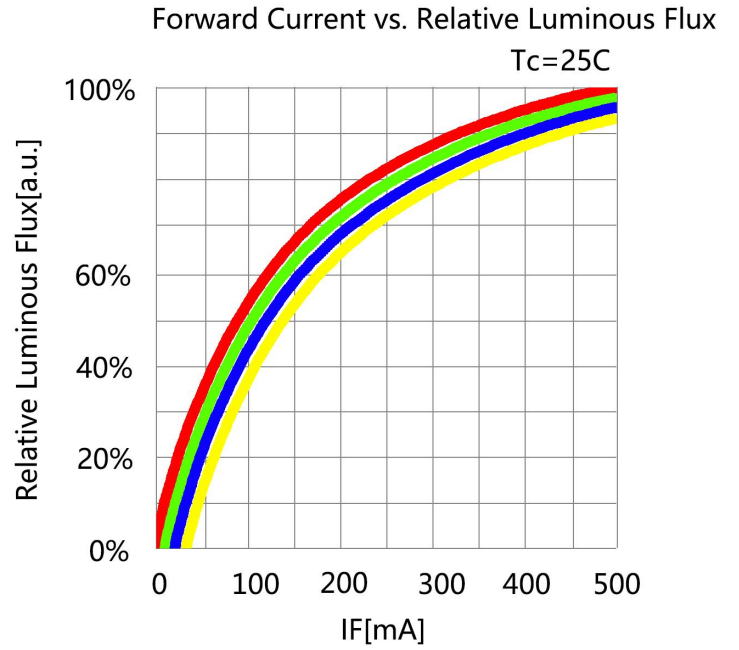
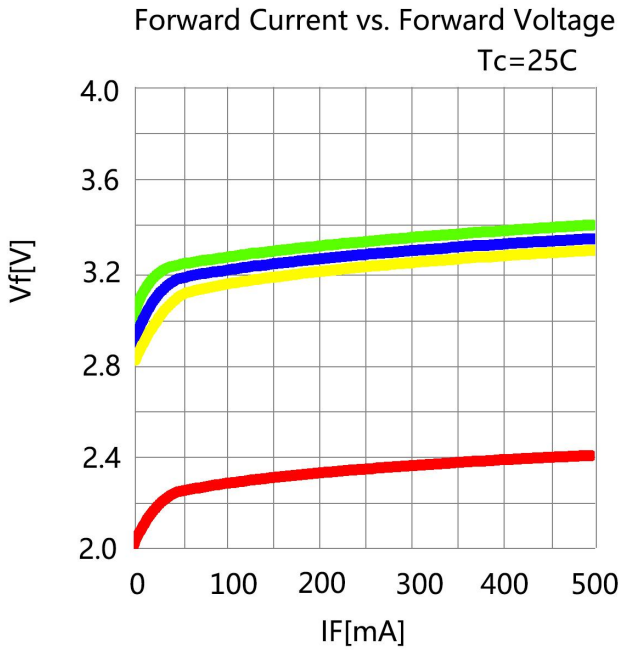

6. Spectrum Curves

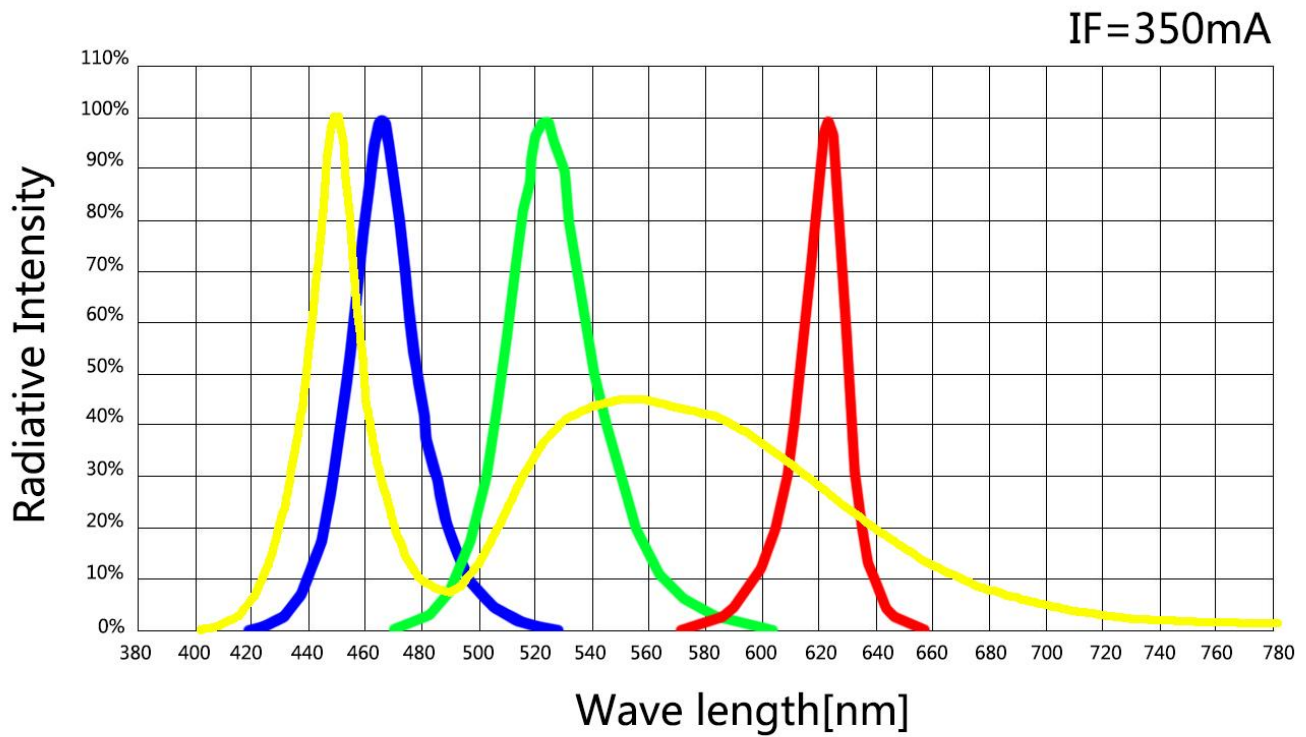

7. Viewing Angle Curves

Radiation Characteristic

IF=350mA

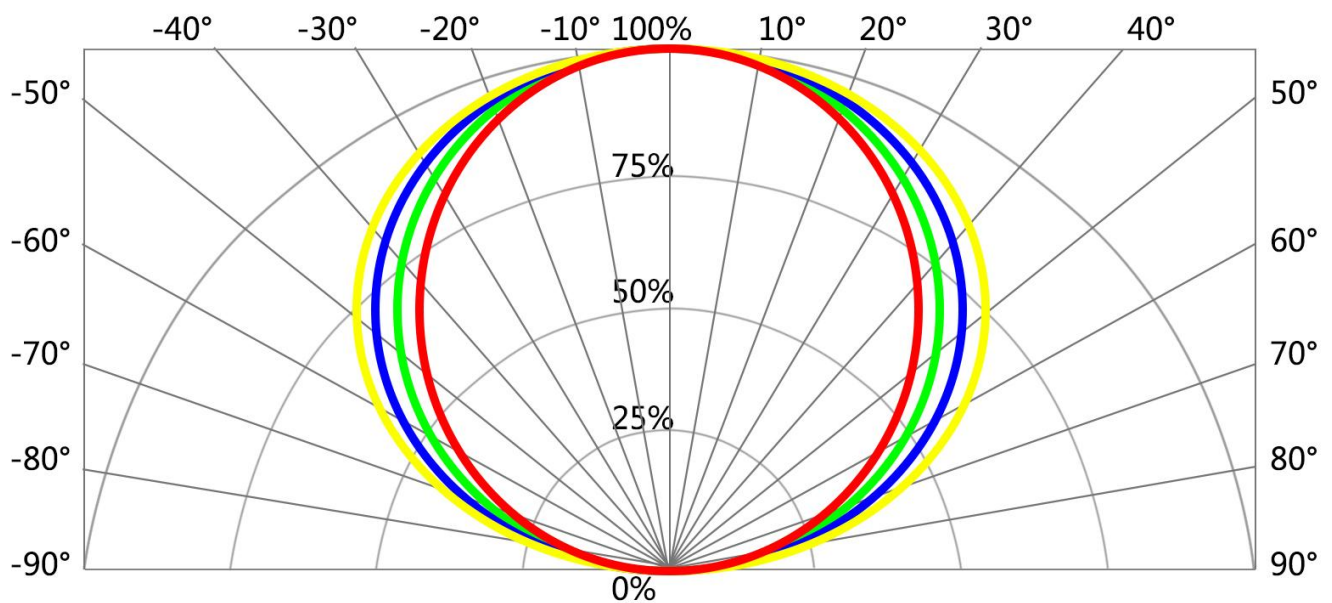

8.Soldering Advice

1. When soldering, don't touch the LED appearance gel during, this bad operation will destroy the LED. Moding LED usually use reflow soldering, please refer to the following reflow temperature curve , and recommend the user follow the soldering temperature curve of the solder paste.

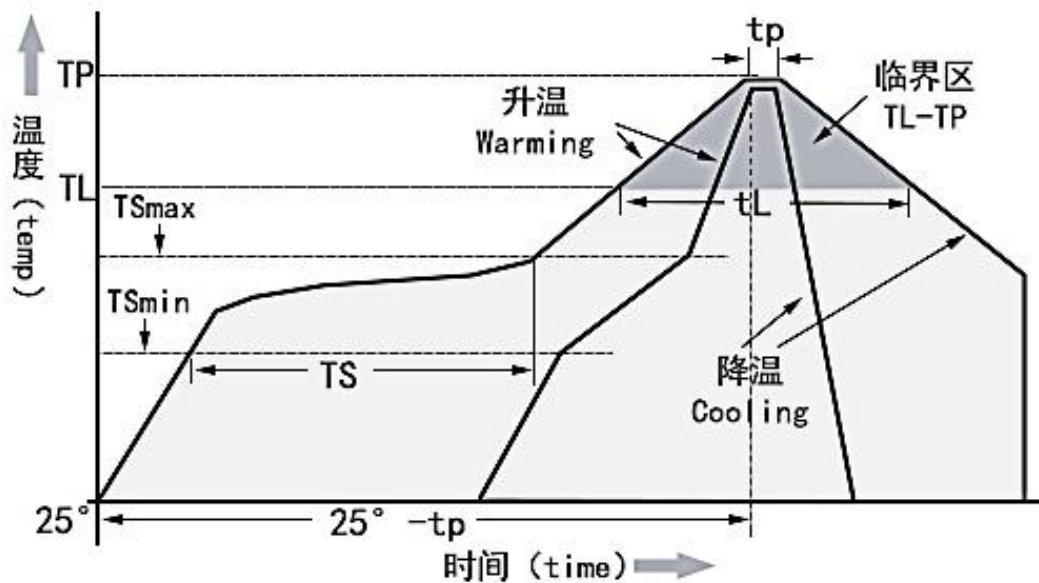

Temperature Curve Character	Lead-free solder
Average heating rate(TSmin to Tp)	最高 3°C/秒 Top 3 °C / s
Preheating: Minimum temperature (TSmin)	90°C
Preheating: Maximum temperature (TSmax)	200°C
Preheating: Time (TSmin to TSmax)	60-180 s
Duration above temperature: Temperature TL	240°C
Duration above temperature: Time tL	60-150 s
Peak/classification temperature (Tp)	260°C
Time within 5°C of actual peak temperature (tp)	20-40 s
Cooling speed	最高 6°C/秒 The highest 6 °C / s
Time to reach peak temperature at 25°C	最多 8 分钟 8 minutes Max

9. Cautions

1. Electrostatic Treatment

Do a full range of anti-static measures (such as: anti-static ring, anti-static clothes, machine, equipment grounding wire, etc.)



2. Heat Dissipation

- A、 It is recommend to configure reasonable heat dissipation device for the product.
- B、 The best working temperature range of the product is 40-60°. It is recommended to control the working temperature of the product within a reasonable range.

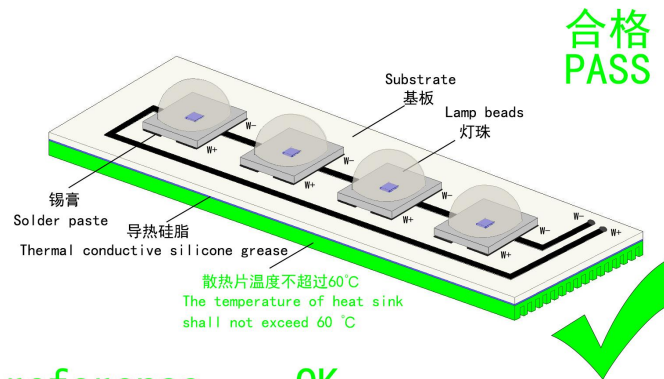

3. Installation Conditions

reference OK

- A、 Do not exert any pressure on the LED area during the use of the led beads. If the machine is used to take materials, select a suction nozzle of reasonable size, such as below:

